



Part NO.	13F 2C A
	

Rate load	Current	10A	
	Voltage	300V	
Dielectrics withstand voltage		2000V/S	
Ambient temperature		-40℃ ~75℃	
Material		Flame Retardant -PA66+GF (V1/V0)	
Material of clip clutch		QSn6.5-0.1	
Installation		PCB	
Accessories		/	
Module		NO	
Packing	Inner packing	Paper box	50PCS
	Outer packing	carton	1200PCS
	Carton size		316*300*225mm
	Weight	IPC	Approximate 7g
ICTN		G. W:9.5KG N. W:8.5KG	

Outside drawing

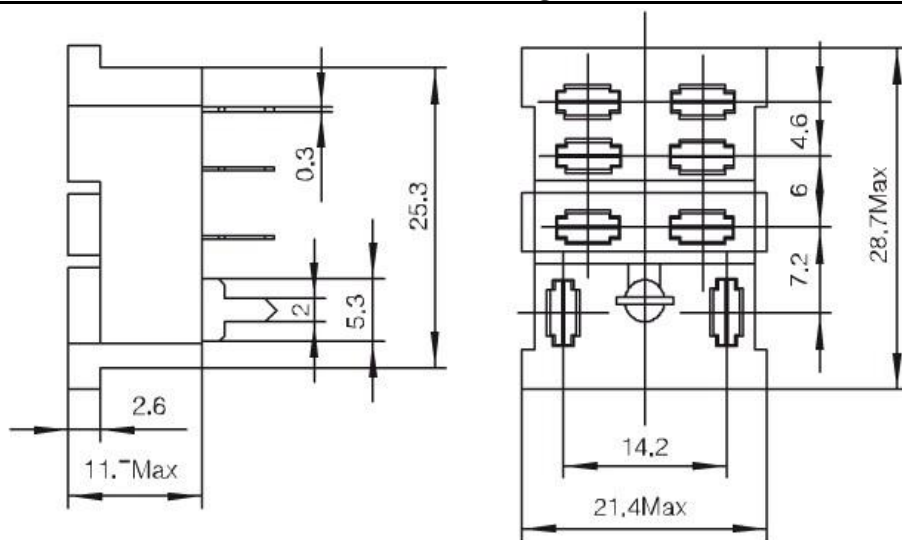

Circuit diagram

